

# IMPACT



WHEN RESEARCH GETS  
**PERSONAL**

*Improving patients' lives through Urology Care Foundation research support | Volume 1*

Copyright © 2019  
Urology Care Foundation, Inc.

## EDITOR

Carolyn J.M. Best, PhD

## MANAGING EDITOR

Erik Siedow

## CONTRIBUTING WRITERS

Kirsten Aquino  
Erik Siedow

## CONTRIBUTORS

Benjamin Canales, MD, MPH; Stephen J. Freedland, MD; Dolores J. Lamb, PhD, HCLD; Dirk Lange, PhD; Michael M. Shen, PhD; Vijaya Vemulakonda, MD; Bernadette Zwaans, PhD

## UROLOGY CARE FOUNDATION BOARD OF DIRECTORS

Harris M. Nagler, MD, FACS (President); Gopal H. Badlani, MD; David F. Green, MD, FACS; Sanford J. Siegel, MD; Mary Ann Lynn Stothers, MD, MHSc; Larry Lipshultz, MD; Raju Thomas, MD; Jay G. Baitler; Ryan D. Drant; Amarpreet Sawhney, PhD

## AUA RESEARCH COUNCIL

Aria F. Olumi, MD (Chair); Rosalyn Adam, PhD; Darius Bagli, MDCM; Christopher Barbieri, MD, PhD; Arthur L. Burnett, MD, MBA; Benjamin Canales, MD, MPH; Toby Chai, MD; Peter Clark, MD; Brock Faulkner; Allen C. Gao, MD, PhD; Ashish M. Kamat, MD; Steven Kaplan, MD; J. Kellogg Parsons, MD; Craig A. Peters, MD; Ganesh Raj, MD, PhD; Robert Reiter, MD; Larissa Rodriguez, MD; Daniel Shoskes, MD; Sunil Sudarshan MD; John T. Wei, MD

For comprehensive urological information, visit [UrologyHealth.org](http://UrologyHealth.org)



American  
Urological  
Association

Education & Research, Inc.

Founded in 1902 and headquartered near Baltimore, Maryland, the AUA is a leading advocate for the specialty of urology with more than 22,000 members worldwide. To learn more about the AUA visit [AUAnet.org](http://AUAnet.org).

*Urology Care*  
FOUNDATION™  
The Official Foundation of the  
American Urological Association

The Urology Care Foundation is the world's leading nonprofit urological health foundation - and the official foundation of the American Urological Association. We partner with physicians, researchers, healthcare professionals, patients, caregivers, families and the public to support and improve the prevention, detection and treatment of urological diseases through research and education.



## EDITOR'S NOTE

On behalf of the American Urological Association (AUA) and our Urology Care Foundation, I am both delighted and honored to help introduce the inaugural issue of IMPACT! Our mission is to increase and maintain the urology physician-scientist and researcher workforce to catalyze the advancement of clinical practice and reduce the burden of urologic disease through impactful research. With the pages that follow, we hope to convey the immense impact of the AUA and Urology Care Foundation support by highlighting some of the talented investigators we are supporting now and over the years and how their research is driving improvements in patients' lives.

Carolyn J.M. Best, PhD  
*Director, AUA Office of Research*

## MORE ONLINE



Visit our website for more information.

[UrologyHealth.org](http://UrologyHealth.org)



View videos from the Urology Care Foundation.

[YouTube.Urology-Health.org](http://YouTube.Urology-Health.org)



Email us for more information

[Research@Urology-Health.org](mailto:Research@Urology-Health.org)



*Follow us on Social Media!*  
[@UrologyCareFdn](https://www.instagram.com/UrologyCareFdn)

# LETTER FROM THE UROLOGY CARE FOUNDATION

On behalf of the Urology Care Foundation Board of Directors, I am excited to present the inaugural issue of IMPACT! This magazine marks the first print publication dedicated to showcasing the breadth and depth of our commitment to research to improve patients' lives.

This issue is packed with remarkable advances in urologic research and you'll have the opportunity to meet some of the incredible researchers the Foundation has funded. You'll learn about the partnerships we have formed with individual donors, medical associations and societies, and industry to achieve our common goal of eradicating urologic illnesses from our communities. In the end, our hope is that this magazine fully illustrates the tremendous impact that we have had on advancing research. We invite you to join us in sharing in that legacy and helping to continue and expand our support for research until suffering from urologic disease becomes our history and no longer our future.

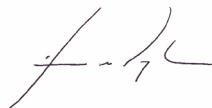

Harris M. Nagler, MD, FACS  
*President, Urology Care Foundation*

# LETTER FROM THE AUA RESEARCH COUNCIL

The American Urological Association (AUA) has been collaborating with its Urology Care Foundation for over 40 years in the shared pursuit of advancing patient care through research, and I am proud to serve as part of this impactful history. We are especially grateful to work with a Foundation that's committed to supporting research funding and education and filling gaps created by an ever-increasing climate of reduced support for research training. With diminished support from other sources, the work of the Foundation in funding urologic research has become critically important to advancing urology and ensuring the best care for our patients.

IMPACT attests to the resolve of this commitment, featuring the urology researchers and physician scientists who are dedicating their careers to improving patients' lives. You'll also learn about how our strategic funding mechanisms and training initiatives position these individuals on the forefront of discovery. We hope you enjoy this snapshot into the world of urologic research and the Foundation's impact on advancing the field and reducing the burden of urologic disease.



Aria F. Olumi, MD  
*Chair, Research Council*



# DEPARTMENTS

## 06

---

### **The Scope**

Learn about the critical need for urologic research.

## 12

---

### **The Faces**

Meet the people making a difference.

## 24

---

### **The Impact**

Explore the progress being made.

## 36

---

### **The Future**

New initiatives to advance tomorrow's practice.

# CONTENTS & FEATURES

## 10

### **Investing in Research Leaders**

Learn how the Urology Care Foundation cultivates research leaders by providing targeted support across the entire career path of a developing research leader.

## 18

### **New Diet Therapy Improves Prostate Cancer Care**

A low carbohydrate diet shows promising results in helping to slow prostate cancer growth.

## 20

### **Cancer Survivorship – When Research Gets Personal**

Dr. Bernadette Zwaans, a radiation cystitis researcher and cancer survivor, shares how her experiences helped shape her research career.

## 26

### **Advancing Patient Care from the Bench to the Bedside**

The Urology Care Foundation funds basic, translational, clinical and outcomes research to ensure that the best research ideas can advance from early discovery to helping patients.

## 28

### **Novel Concepts to Treat Urinary Stone Disease and the Power of Team Science**

Dr. Benjamin K. Canales describes how simple ideas can solve major urologic complications when you have the opportunity to work as part of a research team.

## 32

### **Mentorship Matters – Building Relationships that Bring Discoveries to Patients**

Dr. Dolores J. Lamb explains why quality mentorship is important for any young researcher hoping to make a difference in patients' lives.

## 38

### **Improving Urology Practice with Community-based Research**

Chesapeake Urology Associates is the largest urology practice in the nation and partners with the Urology Care Foundation to involve more community urologists and their patients in research.

## 40

### **Innovations in Ureteral Stent Design Help Patients Recover Faster**

Find out how technological advances in stent design help patients recover faster from urinary stone disease.

## 44

### **By the Numbers**

View a snapshot of how the Foundation's research education and funding initiatives impact urologic science and help shape research leaders to advance tomorrow's practice.

# THE SCOPE

Learn about the  
critical need for  
urologic research.

The Urology Care Foundation is a driving force in the discovery of new treatments because we invest in research leaders. We do more than fund the best research from talented scientists—we help foster and develop their careers to support our strong commitment to finding the next breakthrough in patient care. Investing in these talented physician-scientists and researchers is critical to help catalyze advancements in the prevention, detection and treatment of both benign and malignant urologic conditions.

The Foundation has been on the forefront of urologic discovery since the initiation of its Research Scholar Award program in 1975. This impactful legacy has grown into five different award mechanisms that have supported over 750 young scientists with more than \$30 million in research funding.



13  
12  
11  
10  
9  
8  
7  
6  
5  
4  
3  
2

14  
13  
12  
11  
10  
9  
8  
7  
6  
5  
4  
3  
2

ASUTERVING

# The Impact of Urologic Disease

**1 IN 9**

men will develop **PROSTATE CANCER** in his lifetime.

This rate is higher among African American men.

**1+ million**

people visit the emergency room for **KIDNEY STONE** problems every year.

Approximately **80,000**

new cases of **BLADDER CANCER** are diagnosed each year.

**33 million**

men and women suffer from **URINARY INCONTINENCE.**

**1 IN 200**

**BABIES** will be born with **HYPOSPADIAS**, making it one of the most common birth defects.

**INFERTILITY** impacts **15%** of couples and male factors are present in **50%** of these couples.

**20%**

of women will experience at least **ONE UTI** in their lifetimes.

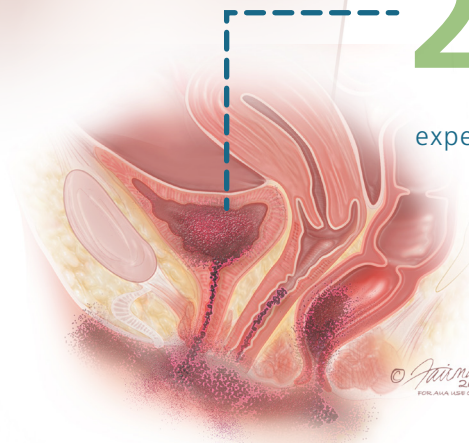



# Our Commitment

The Urology Care Foundation is committed to improving patients' lives by investing in research where it's needed the most.

Biomedical research in the United States has been negatively impacted by the economic climate, with urology being hit particularly hard, as research in this area has been underfunded compared to other disease groups. Our support has never been more critical given current gaps in federal research funding, academic budget constraints that limit research capabilities in urology departments across the country, and the rapidly increasing burden

of urologic diseases on the nation as the population ages.

Research is the cornerstone for any advances in the prevention, detection and treatment of urologic disease, and the Foundation is committed to funding cutting-edge research and fostering the development of researchers who make it possible.

## Cutting-Edge Research

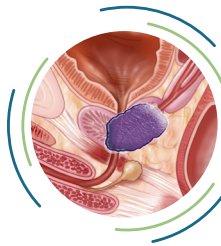

### Prostate Cancer

Using microRNAs released into the blood to develop early detection strategies for metastatic prostate cancer.

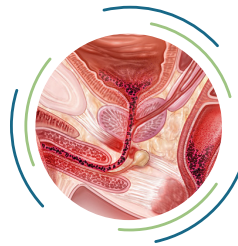

### UTI

Targeting bacterial iron acquisition as a non-traditional UTI treatment strategy to reduce incidences of antibiotic resistance.

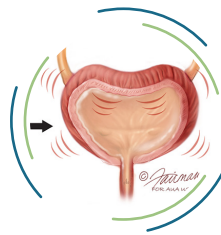

### OAB/Incontinence

Exploring electrical stimulation to address neuromuscular control of the urethra associated with forms of urgency urinary incontinence.

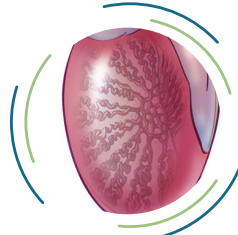

### Infertility

Investigating the outcomes of assisted reproductive technology in cases of male infertility and the impact of health insurance coverage.

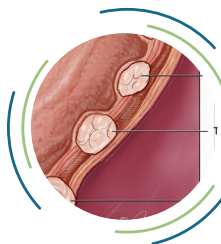

### Bladder Cancer

Evaluating how surgery-induced stress alters a patient's responsiveness to immunotherapy following bladder cancer surgery.

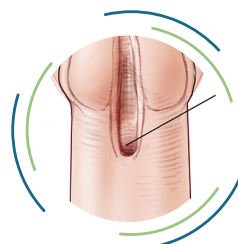

### Sexual Development

Identifying genetic mutations that cause urologic birth defects such as hypospadias and prune belly syndrome.

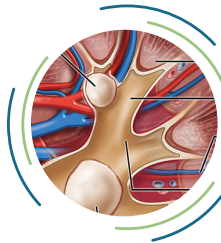

### Kidney Stones

Developing a dipstick test that measures urine oxalate levels to improve kidney stone treatment.

# Investing in Research Leaders

The Urology Care Foundation has established a portfolio of mentored training awards that recruit young urologists and scientists into research and provide the critical support to develop research leaders. These awards follow the path of a urology research career in order to help retain the most talented individuals in the field. Similar to the National Institutes of Health (NIH), the Foundation uses a rigorous peer-review process that enlists a group of urology research experts who evaluate the quality and impact of every project before it's funded, as well as the applicant's potential to become a future leader in the field.

THE FOUNDATION HAS SUPPORTED OVER

## 750 Physician Scientists and Researchers

WITH MORE THAN

## \$30 million

IN RESEARCH FUNDING.

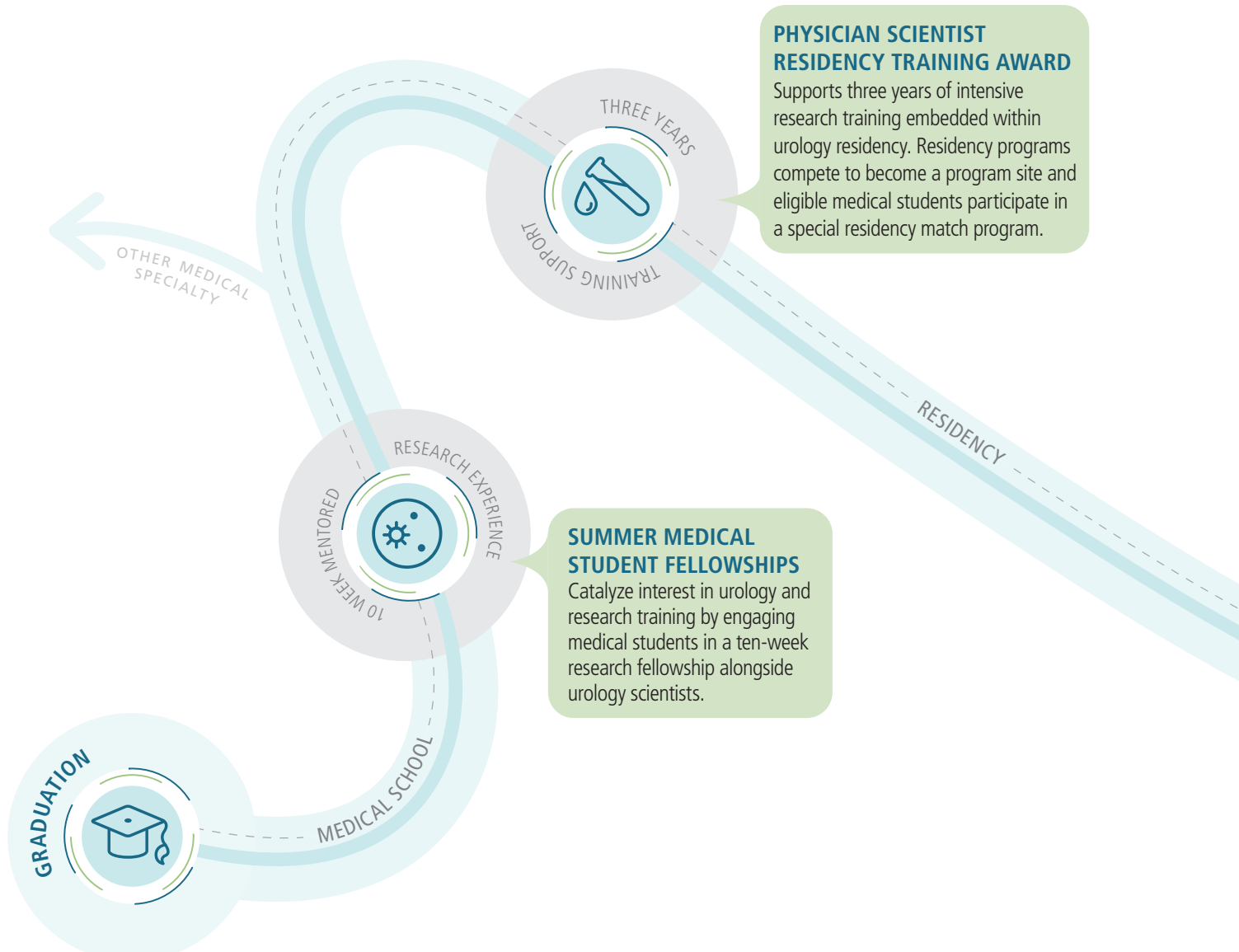

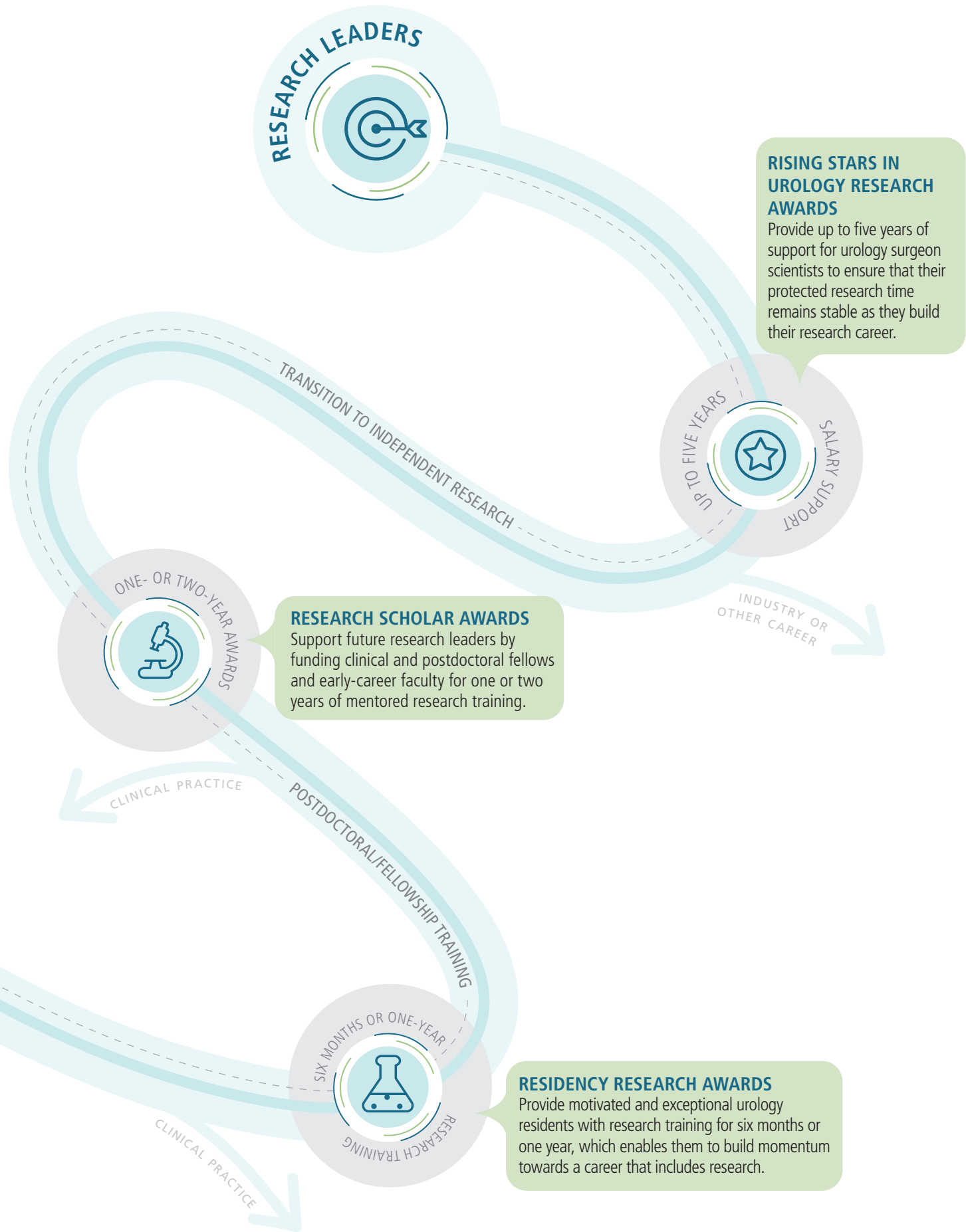

# THE FACES

Meet the people  
making a difference.

Investing in research means investing in people, and the Urology Care Foundation is committed to ensuring that the best and brightest researchers have the necessary training and resources to make a difference in patients' lives. Surgeon scientists dedicate their careers to balancing a demanding clinical workload along with a passion for discovering better ways to treat their patients. Basic scientists choose to apply their expertise in laboratory techniques to better understand the underlying biology of urologic conditions and enable the development of new treatments. Senior physician scientists and researchers give their time and energy to mentor the next generation of talented urology researchers. Through early mornings, late nights and weekend hours, innovation in patient care rests on the shoulders of these tireless, devoted individuals.





Zwaans, PhD

Beaumont

Elijah Ward  
Urology

Beaumont

Laura Lamb, PhD  
Urology

# Supporting Research For Over 40 Years

The Urology Care Foundation Research Scholar Award program has had a tremendous impact on improving patient care. Since 1975, this flagship program has invested over \$25 million to support over 600 Research Scholars, most of whom now serve as leaders in urologic research and clinical practice. Our targeted approach to funding impactful research *and* potential research leaders has helped shape the field of urology to improve patient care.

## CELEBRATING RESEARCH SCHOLARS ACROSS FOUR DECADES



Charles Brendler, MD  
1980–1982 Research Scholar

Recently retired, Dr. Brendler made major contributions to the field of prostate cancer, particularly regarding the technique of radical prostatectomy and helping to identify the genes associated with prostate cancer risk and lethality. From 1993-2006, he served as Professor and Chief of Urology at the University of Chicago and from 2006-2017 as Vice Chairman of Surgery for Research and Director of the Program for Personalized Cancer Care at NorthShore University HealthSystem in Evanston, IL. Recognizing the importance of investing in future research leaders, Dr. Brendler has ‘paid it forward’ by supporting the Urology Care Foundation Summer Medical Student Fellowship program and honoring his father, who was also a urologist committed to educating future leaders, through the Herbert Brendler, MD Summer Medical Student Fellowship Fund.

1975

Arthur L. Burnett, MD, MBA  
1994–1996 Research Scholar

Dr. Burnett has become a world-renowned expert in sexual medicine with a focus on lower genitourinary conditions and reconstruction, erectile dysfunction, and penile abnormalities. His Foundation-supported research on nitric oxide and carbon monoxide as mediators of the urogenital system was critical to the development of medications to treat erectile dysfunction such as VIAGRA®. Dr. Burnett is now a distinguished Professor of Urology and Director of the Basic Science Laboratory in Neuro-urology at Johns Hopkins University.



1985



### Tomas Griebing, MD, MPH 1997–1999 Research Scholar

Dr. Griebing currently holds the John P. Wolf 33<sup>rd</sup> Masonic Distinguished Professorship in Urology at the University of Kansas (KU) School of Medicine where he is also a Faculty Associate in The Landon Center on Aging. He recently served KU for several years as the Senior Associate Dean for Medical Education. His work as a Research Scholar helped to establish him as a leader in aging-related voiding dysfunction research, specializing in areas including epidemiology, clinical outcomes and urodynamics. In 2017, he received the Distinguished Service Award from the American Urological Association for his work in the field. He has a passion for teaching and training other surgeons and urologists as a way of giving back.

1995

2005

2015

### Kristina Penniston, PhD, RDN 2008–2010 Research Scholar

Dr. Penniston is now a senior scientist and clinical nutritionist at the University of Wisconsin. The Research Scholar Award program gave her the opportunity to study nutritional strategies to prevent recurrent stones, and to develop and pursue the emerging area of the health-related quality of life for patients with urolithiasis. Dr. Penniston's award was a catalyst for the development of the Wisconsin Stone Quality of Life questionnaire and spurred the formation of the North American Stone Quality of Life Consortium, current efforts of which include identifying how to use patient-reported outcomes to improve care.



## *Foundation Firsts*

Celebrating the inaugural issue of IMPACT by acknowledging some of the Urology Care Foundation's "Firsts."

---

Larry Lipshultz, MD



### One of the First Research Scholar Awardees, 1975

Dr. Lipshultz became an early pioneer in male infertility research with what began as a two-year study of Sertoli cells and their role in spermatogenesis. He is now a world-renowned urologist, especially in men's health, and has helped transform the field on topics ranging from testosterone replacement therapy to microsurgery.

---

*“Being a Urology Care Foundation Research Scholar was probably the most impactful two years of my career. Under the supervision of an exceptional mentor, Emil Steinberger, I was able to generate the data I needed to successfully apply for a major National Institutes of Health grant. Other grants followed and a productive commitment to academic urology began.”*

**Larry I. Lipshultz, MD**

*Professor of Urology*

*Lester and Sue Smith Chair in Reproductive Medicine*

*Chief, Division of Male Reproductive Medicine and Surgery*

---



Margaret Pearle, MD, PhD



## First Female AUA Gold Cystoscope Winner, 2003 Research Scholar Awardee, 1991

Dr. Pearle was presented with the AUA Gold Cystoscope Award for her outstanding contributions to patient care in the area of stone disease. She now holds the Distinguished Chair in Urologic Education at UT Southwestern Medical Center and is a leader in endourology and minimally invasive techniques.

Lysanne Campeau, MDCM, PhD



## First Female Astellas Rising Stars in Urology Research Awardee, 2015

Overactive bladder treatment is currently limited to medicines that alleviate symptoms, many of which are poorly tolerated by patients. Rather than focusing on the symptoms, Dr. Campeau is exploring metabolic syndrome as a potential cause of overactive bladder in order to develop new therapeutic strategies that treat the disease.

Simpa Salami, MD, MPH



## First Specialized Programs of Research Excellence Research Scholar Awardee, 2016

This award is dedicated to supporting a urology physician-scientist at a National Cancer Institute (NCI) Specialized Programs of Research Excellence (SPORE). Working at the University of Michigan, Dr. Salami's research is focused on developing optimal paradigms for early detection of prostate cancer and accurately stratifying patients into risk categories to improve active surveillance and treatment response.



## *New Diet Therapy Improves Prostate Cancer Care*

“While I am trying to answer several overarching questions related to prostate cancer, one of my key areas of focus is on lifestyle choices,” writes Stephen J. Freedland, MD, a distinguished professor of urology at Cedars-Sinai in Los Angeles, California. “Specifically, I’m interested in understanding how factors such as diet, exercise and obesity impact prostate cancer development and progression.”

Dr. Freedland was an inaugural recipient of the Urology Care Foundation Rising Stars in Urology Research Award in 2005, which was made possible in part by the generous support of Astellas Pharma US, Inc. As a physician scientist, this award afforded him additional time away from clinical duties to focus on establishing his own research program.

“My interest in this line of research started with observing that obese men have more aggressive cancers,” Freedland continues. “With support from the Urology Care Foundation, we tested whether various diets could slow prostate cancer growth. We discovered that a very low carbohydrate diet slowed prostate cancer growth, which we then validated in multiple tumor models. This produced the promising data we needed to begin our first clinical trial. This recently completed trial showed that a very low carbohydrate diet blocks many of the side effects of hormonal therapy for prostate cancer. A second trial testing whether this diet can slow the growth of recurrent prostate cancer is nearing completion.”

“Many patients come to me saying they read my papers for dietary advice about their cancer. Sometimes they have already started a low carbohydrate diet and can quote my papers back to me line-by-line! It is very gratifying to know that we are breaking new ground and challenging conventional wisdom that only a low fat diet is effective against prostate cancer. While this may still be effective, it’s important that we’re able to explore alternative diet therapies and find new opportunities to improve patient care. And, at the end of the day, none of these successes would have been possible without the support of the AUA and its Urology Care Foundation so early in my career,” states Freedland. ●

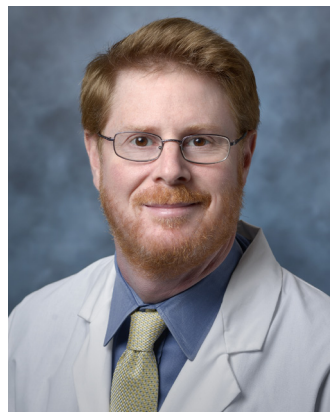

Stephen J. Freedland, MD

“...none of this would have been possible without the support of the AUA and its Urology Care Foundation so early in my career.”



Vijaya M. Vemulakonda, MD

## *Practice Guidelines Save Lives: Standardizing Pediatric Care for UPJ Obstruction*

Dr. Vijaya Vemulakonda specializes in treating pediatric urologic conditions and one of her main research interests is finding better ways to treat infants born with ureteropelvic junction (UPJ) obstruction. UPJ obstruction occurs when there is a blockage in the patient's ureter where it joins the kidney, which restricts the flow of urine and can lead to swelling of the kidney. Despite the prevalence of this disease in children, there has been little research into the roles of both parents and surgeons in the decision-making process for treating this condition, or the impact of parental and surgeon preferences on treatment.



With the combined support of a Urology Care Foundation Rising Stars in Urology Research Award and an Agency for Healthcare Research and Quality (AHRQ) Career Development Award, Dr. Vemulakonda will explore how different factors influence treatment variations in infants with suspected UPJ obstruction. Her goal is to leverage these data to develop evidence-based guidelines to improve pediatric care.

Dr. Vemulakonda's lab conducted interviews with parents and pediatric urologists of infants with suspected UPJ obstruction. She found that parents and surgeons agreed that decisions for treatment should be shared, but that the surgeon was best equipped to guide the decision. Surgeons recognized a lack of data regarding the optimal indications for surgery, using their own experience and personal algorithms to fill this gap. Overall, both parents and surgeons were satisfied with their role in the decision-making process. Dr. Vemulakonda's team is now using these findings to inform a multi-center prospective study.

Nearly one year into her award, Dr. Vemulakonda writes, "The Urology Care Foundation Rising Stars Award helped protect my research time and improved the sustainability of my research career. This support has played a major role in driving the success of my research efforts to date." ●

"The Urology Care Foundation award helped protect my research time and improved the sustainability of my research career. This support has played a major role in driving the success of my research efforts to date."



# CANCER SURVIVORSHIP — WHEN RESEARCH

# *gets Personal*

4 <sup>th</sup> floor	
Infectious Disease 401	Stem Cell Bank 408
Orthopaedic Research Labs 402	Tissue Bank for Cell Biology 408
Biomechanics & Implant Analysis 402	Advanced Microscopy 409
Orthopaedic Research Office 404	Genomics 410
Radiation Oncology Research Lab 403	Proteomics 411
Radiation Oncology Research Offices 415	Offices/Informatics 412



Cancer is a serious diagnosis that can lead to life-altering experiences, but for some, it is no longer the death sentence it used to be. Current estimates suggest there are now over 15.5 million cancer survivors living in the U.S., where more and more people are surviving the disease rather than dying from it. This statistic is an important testament to the many years of hard work and ingenuity by medical researchers, doctors and their patients across the globe. However, cancer survivorship often results in a new set of problems and complications that need to be investigated. Few people know this better than Dr. Bernadette Zwaans, assistant professor in urology at Oakland University School of Medicine, Urology Care Foundation Research Scholar, and a cancer survivor herself.

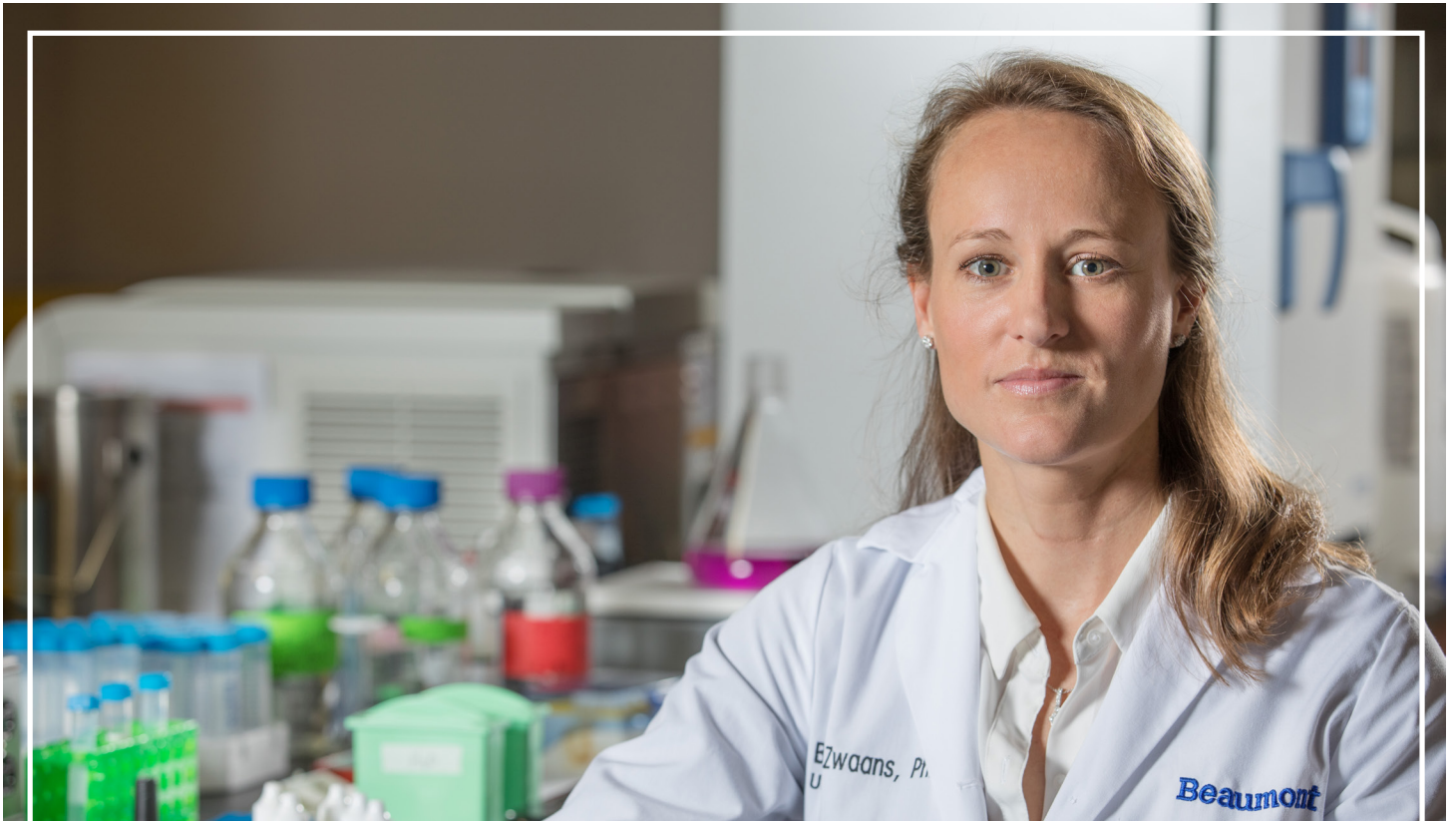

Dr. Zwaans' interests have always steered her toward the sciences, starting with a degree in biological health sciences in the Netherlands. After obtaining her Master's degree, she moved to the U.S. to work at Harvard Medical School researching tumor angiogenesis, or how tumors survive through developing their own blood supply. However, Dr. Zwaans' research took a personal turn when her father was diagnosed with cancer.

Her father was fortunate and survived his cancer diagnosis due to a drug that was developed at Harvard—Dr. Zwaans happened to work down the hall from one of the doctors who developed the drug that saved his life. Her father became a huge believer in the importance of medical research, and this further energized Dr. Zwaans in pursuit of her own career.

To continue her research in the cancer field, Dr. Zwaans decided to pursue a PhD in molecular and cellular pathology at the University of Michigan. During her time there, she studied both human and animal models of colon cancer. After earning her PhD, she accepted a postdoctoral position in the Department of Urology at Beaumont Hospital working in a lab focused on radiation cystitis. Radiation cystitis, a known side effect of radiation therapy for cancer, negatively impacts the bladder and leads to painful and disruptive symptoms for the patient.

Shortly after starting her research at Beaumont, Dr. Zwaans received her own diagnosis of cancer. She learned that she too would have to undergo radiation therapy not only during a crit-

ical stage in her research but also as a new mother. Fortunately, her treatments proved to be successful. Dr. Zwaans is now both professionally and personally aware of how important survivorship issues are to patients, and her journey with cancer has strengthened her commitment to urologic research.

In July 2018, Dr. Zwaans was awarded a Mentored Research Scientist Career Development Award from the National Institutes of Health for her research in radiation cystitis. This highly-competitive federal grant is designed to support young investigators like Dr. Zwaans and help develop their research careers. While this grant will give her the financial support and resources to continue her research, she also believes this is an excellent indication that cancer survivorship issues are being recognized as a major health care concern for which more research is needed.

While the therapy Dr. Zwaans received for her cancer diagnosis did not cause radiation cystitis, she is still at risk for developing radiation-induced, long-term side effects to other organs, just like many patients who have battled cancer. Unfortunately, there are currently no cures or treatments for these long-term complications caused by radiation therapy, but Dr. Zwaans aims to change that. Working with her team at Beaumont Health, Dr. Zwaans is investigating how radiation therapy damages the vasculature in the bladder. One of the serious complications in patients with radiation cystitis is uncontrollable bleeding in the bladder. In some of the more serious cases, the urologist has to

*"...there are currently no cures or treatments for these long-term complications caused by radiation therapy, but Dr. Zwaans aims to change that."*



Bernadette Zwaans, PhD  
2015 Urology Care  
Foundation Research  
Scholar Award Recipient

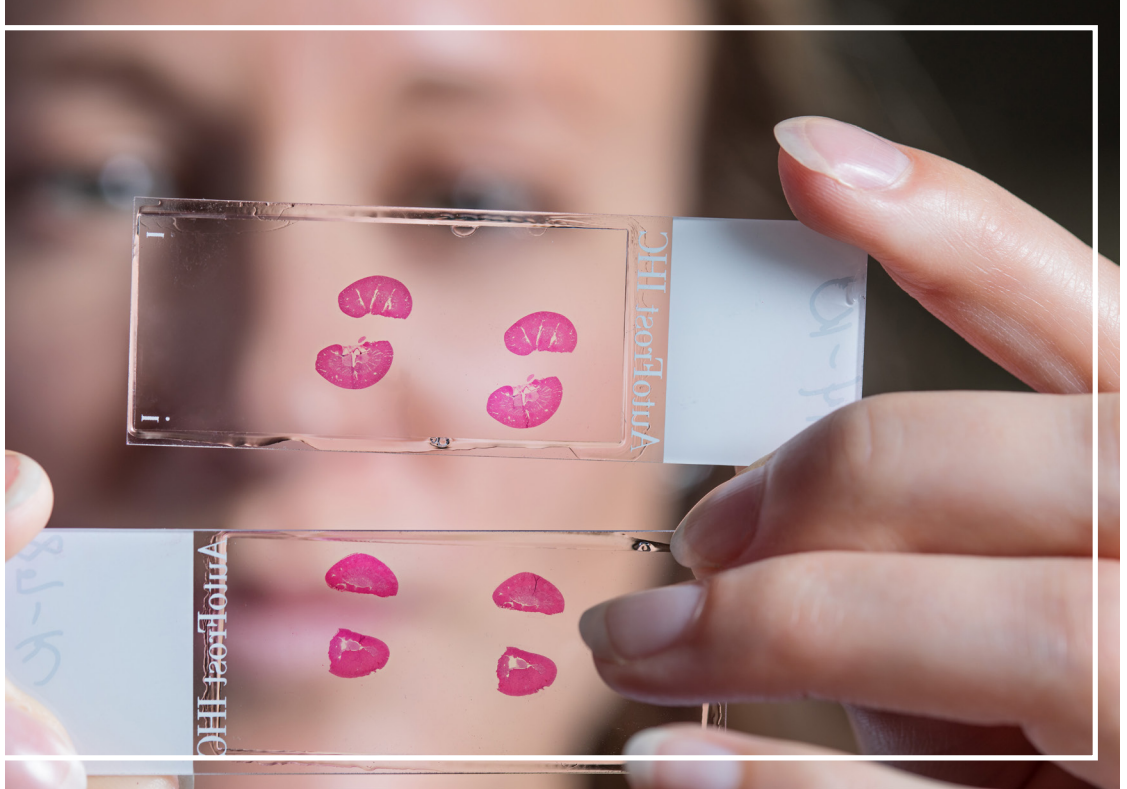

remove the bladder altogether. Dr. Zwaans and her team are working to identify biomarkers that detect early changes in vascular health, which may result in new therapeutic strategies to prevent the progression of further damage to the bladder.

As she was beginning her work in radiation cystitis at Beaumont Health, Dr. Zwaans was awarded a Research Scholar Award from the Urology Care Foundation, which provides critical support to promising young investigators and future research leaders. According to Dr. Zwaans, the Foundation played an important role in fostering her development as a urologic researcher. She was also invited to participate in the Urology Care Foundation-supported Early-Career Investigators Workshop. This workshop gave Dr. Zwaans the opportunity to fine-tune her grant writing skills with urology research experts in order to help prepare her first National Institutes of Health grant. This support, along with Dr. Zwaans' research

excellence, perseverance, and commitment to future patients, have combined to ultimately lead to her success.

Discoveries in understanding radiation cystitis could also lead to applications in other parts of the body and prove beneficial for other cancer survivors suffering from the side effects of radiation therapy. Dr. Zwaans knows that it's a long road to developing an independent research lab. However, knowing that she has the confidence of the Urology Care Foundation and the National Institutes of Health, along with others in the field, has fortified her commitment to research. She believes having a positive attitude and turning bad experiences into good are essential to succeeding in science. Her ultimate goal is to help as many people as possible through her commitment to research.

More information on Dr. Zwaans' research studies can be found at [happybladder.org](http://happybladder.org). ●

# THE IMPACT

## Explore the progress being made.

The Urology Care Foundation supports innovative researchers who are positioned to make significant contributions from the laboratory bench to the patient's bedside. These individuals work to advance urology across every stage of therapeutic development—from basic science discoveries and translational applications to clinical testing and surgical outcomes. In addition to providing financial resources, the Foundation also ensures that each funded investigator is paired with an exceptional mentor who can provide the necessary training and guidance for a successful research career. This funding strategy ultimately has an enduring impact on improving patients' lives by supporting critically-needed research now, while also fostering the development of an individual who is committed to finding the next breakthrough in patient care.







# Advancing Patient Care from the Bench to the Bedside

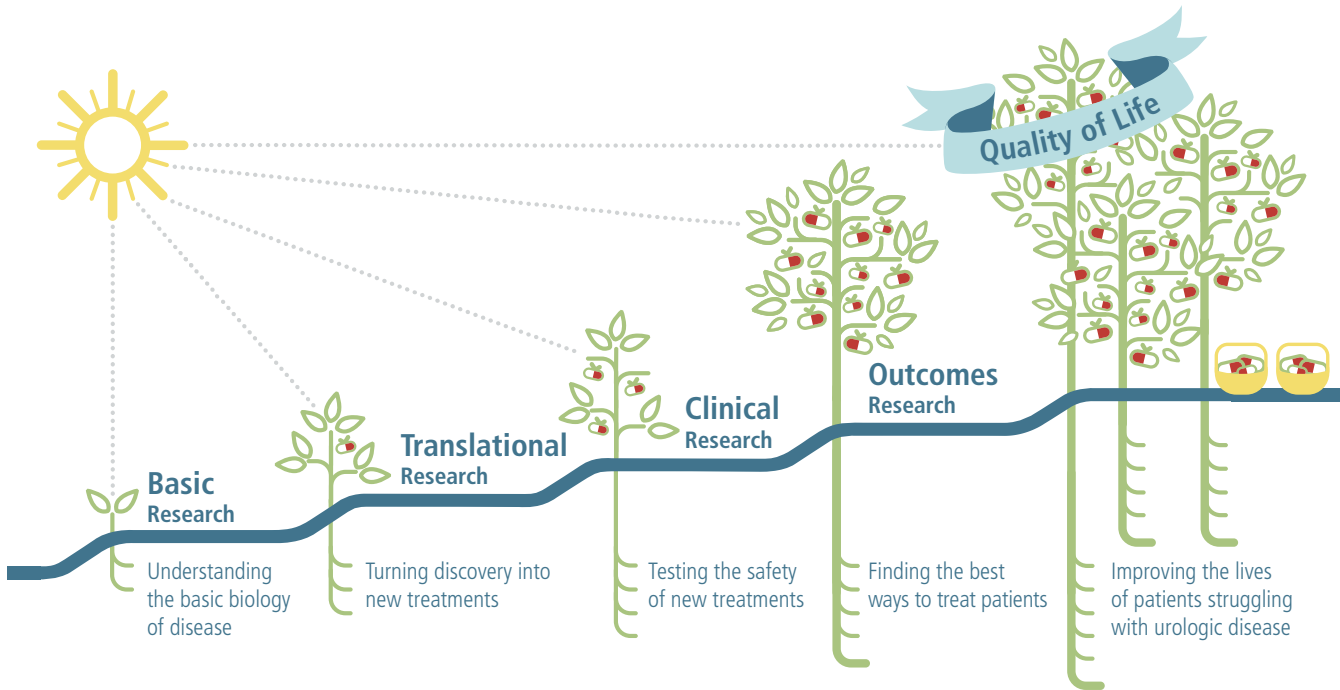

It can take over 15 years and more than \$2.5 billion before a new drug or therapy is approved for patient use. Although these figures seem overwhelming, the Urology Care Foundation provides support for only the best and most-promising studies across every stage of development. This ensures that early research discoveries have the best chance to ultimately reach patients and improve their lives. Our commitment to kidney cancer research illustrates the impact of this investment strategy for improving patient care.

## BASIC RESEARCH



### Brian Chapin, MD

*Research Scholar, 2010-2011*

Tyrosine kinase inhibitors (such as Sunitinib), a class of anti-cancer drugs, have been effective in treating kidney cancer through anti-angiogenesis, a process that kills blood vessels that surround the cancer cell, leading to stabilization or regression of the disease. Unfortunately, these effects can be short lived as the cancer develops resistance and continues to progress. To determine the cause of this resistance, Dr. Chapin focused on the response of endothelial cells, which are cells that line blood vessels and are necessary for their formation, to a particular group of tyrosine kinase inhibitors as a mechanism of angiogenic escape. His work laid the foundation for better understanding molecular changes in developing resistance to therapy, which may lead to the discovery of new targets for future drug intervention.

## TRANSLATIONAL RESEARCH



### Vivek Narayan, MD

*Research Scholar, 2017–2018*

Dr. Narayan sought to develop a non-invasive method to predict a patient's response to immune checkpoint inhibitor therapy during the early stages of treatment for metastatic kidney cancer. He designed a blood test that measures important changes in a patient's T cells, circulating tumor material and other clinical findings, which will be analyzed in a prospective cohort of 40 patients. As patient recruitment in his study nears completion, Dr. Narayan will also include samples from patients receiving tyrosine kinase inhibitor therapy to evaluate any differences between the two. Dr. Narayan's early successes supported by the Foundation have enabled him to serve as the Principal Investigator on three early-phase clinical trials looking at immune-oncologic agents for advanced kidney cancer.

## CLINICAL RESEARCH



### Brandon Manley, MD

*Research Scholar, 2018–2020*

There are a number of drugs that use the body's immune system to help fight cancer, also known as immunotherapy, that have been successful in treating patients with kidney cancer. Unfortunately, these treatments aren't effective for everyone. Dr. Manley is analyzing tissue samples from kidney cancer tumors to discover genetic and immunofluorescence markers that could signal which patients will respond to a given drug. This would help doctors identify patients who could benefit most from these treatments early in their disease, thereby maximizing its effectiveness. It will also allow patients who are unlikely to benefit from immunotherapy drugs to go straight to targeted treatments that are more likely to be effective for their individual disease.

## OUTCOMES RESEARCH



### Shannon Cannon, MD

*Residency Research Awardee, 2016–2017*

Dr. Cannon designed a study to understand how disparities in access to kidney cancer care are associated with an established disparity in cancer-specific outcomes for racial and ethnic minorities. Her research explored different variables and practice patterns that impact a patient's access to nephron-sparing surgery, a treatment that is considered optimal for most patients. Dr. Cannon has decided to continue her emphasis on health disparities into fellowship where she will focus on pediatric urology.

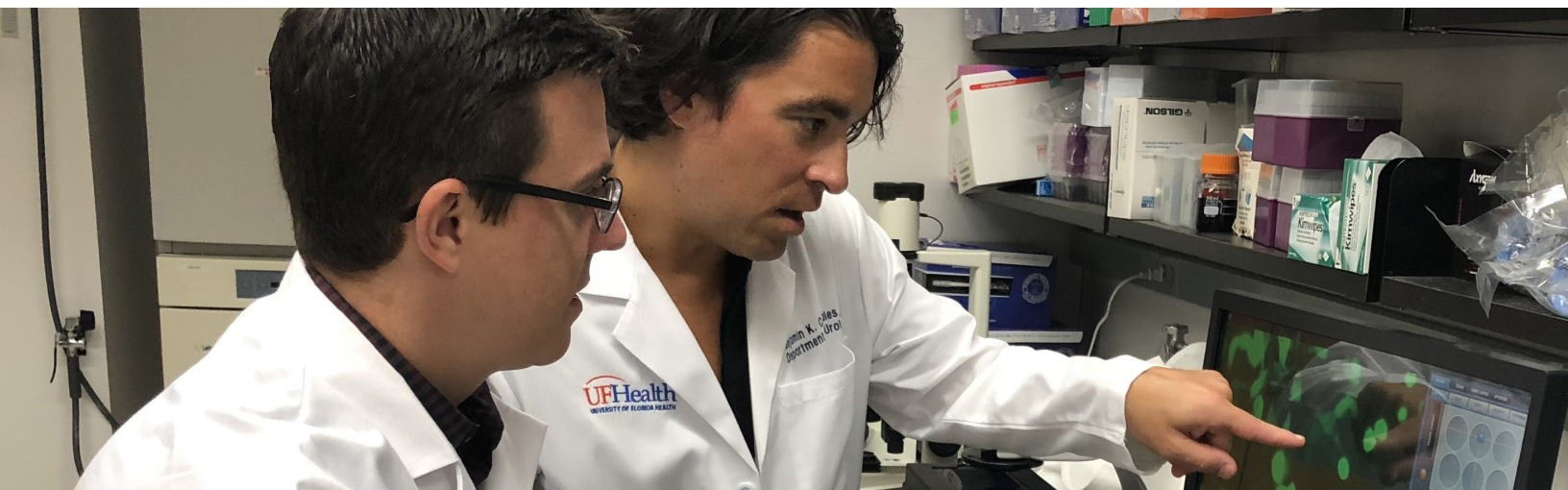

William L. Donelan, PhD (left) and Benjamin K. Canales, MD, MPH (right)

## *Novel Concepts to Treat Urinary Stone Disease and the Power of Team Science*

Benjamin K. Canales, MD, MPH learned that team science was a great way to advance simple ideas during his urology fellowship at the University of Minnesota. He had an idea to use a mass spectrometer to identify kidney stone matrix—the proteins that glue crystals together—but knew nothing about the science of proteomics. Fortunately, his Urology Care Foundation Research Scholar Award gave him the resources needed to assemble a group of scientists to study this topic in a novel way. Under the mentorship of Manoj Monga, MD and LeeAnn Higgins, PhD, Dr. Canales’s simple idea bloomed into a field where new drugs are being designed to inhibit stone matrix proteins and, as a result, kidney stones themselves.

Over the last ten years since his fellowship, Dr. Canales has tested a number of therapies for enteric (intestinal) hyperoxaluria, a condition that involves excessive absorption of oxalate (a nutrient in many common foods) from the gastrointestinal tract. Too much of this mineral in urine can lead to stones, nephropathy and end-stage kidney disease, but the underlying mechanisms behind these conditions are difficult to study in humans. With support provided by a Urology Care Foundation Rising Stars in Urology Research Award, Dr. Canales worked with a team at the University of Florida to create a model of enteric hyperoxaluria to understand the development of urinary stones in humans in search of a cure. Their collaborative efforts ultimately discovered that the gut bacteria *Oxalobacter formigenes* could bring urine oxalate back down to a normal level, thereby reducing incidence of stone formation. According to Dr. Canales, “We found that *Oxalobacter* was literally forcing intestinal cells to pull oxalate out of the bloodstream and back into the gut lumen in order for

this bacteria to use it as an energy source...a finding that is now being tested in human clinical trials.”

As an independent investigator now with a lab of his own, Dr. Canales is an active mentor for postdoctoral fellows and trainees performing kidney stone research, some of whom have become Urology Care Foundation awardees as well. He is currently serving as a mentor for William L. Donelan, PhD, a 2018-2020 Research Scholar Awardee, who is developing a dipstick test for urine oxalate levels. This simple and inexpensive test may revolutionize monitoring and treatment for kidney stones by providing real-time information for both patients and clinicians.

“Simple ideas, team science and unwavering support from the Urology Care Foundation have made my career possible, and I’m excited to see how kidney stone disease research will advance over the next 10 years through their support!” he said. ●

“Simple ideas, team science and unwavering support from the Urology Care Foundation have made my career possible, and I’m excited to see how kidney stone disease research will advance over the next 10 years through their support!”

# Tumor Avatars – A New Path to More Effective Cancer Treatments

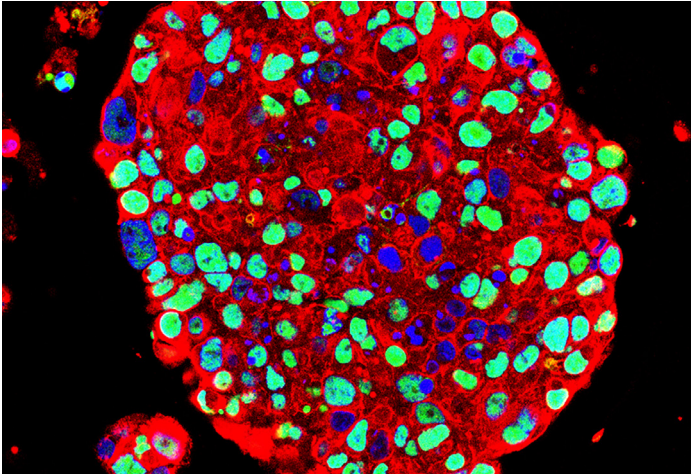

Bladder cancer organoids

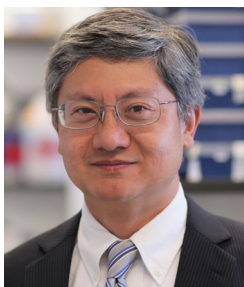
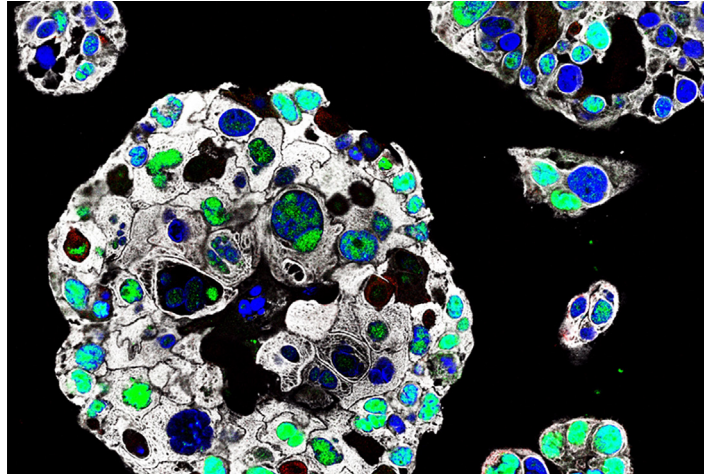

Michael M. Shen, PhD

Cancer is a complex disease that develops, evolves and responds to treatment in different ways that can vary unpredictably between patients, even those with the same disease. Michael M. Shen, PhD at Columbia University Medical Center, has teamed up with several Urology Care Foundation-funded researchers to help solve this problem.

Dr. Shen's laboratory specializes in research on stem cells, which are cells that can give rise to many other cell types, and he has used this approach to better understand prostate and bladder cancer. Dr. Shen's team achieved a major breakthrough when they successfully created an "organoid" model of a normal prostate gland. Organoids are "mini-tissues" that are similar to the cell types and tissues found in the body. Dr. Shen's team went on to show that organoids could be developed from living cancer cells, which set the stage for creating specific models of prostate cancer that are similar to different types of human prostate cancer. These could then be used to study, outside of the body, the different ways the disease may progress and how best to stop its progression.

More recently, Dr. Shen's team expanded this work to study bladder cancer and successfully developed approaches for generating organoids with bladder cancer using a sample from a pa-

tient's tumor. These organoids serve as patient-specific "avatars" of the original tumor and can be screened for their response to a wide range of drug treatments. Ongoing research in the lab is examining whether the drug responses of patient-derived organoids resemble the responses observed in patients. If so, the establishment and analysis of patient-derived organoids will represent an important step in designing precision therapies (or 'personalized medicine') for patients with bladder cancer.

According to Dr. Shen, the Urology Care Foundation played a critical role in this research by supporting three of his trainees. Flaminia Talos, MD, PhD, a 2012 Research Scholar Awardee, used organoids to investigate the mechanisms that promote prostate tumor progression. LaMont J. Barlow, MD, a 2013 Residency Research Awardee, initiated efforts to grow organoids from samples of bladder tumors from patients. Most recently, 2016 Research Scholar Awardee Suk Hyung Lee, PhD, characterized and performed drug screening on patient-derived bladder tumor organoids.

Thanks to the combined efforts of Dr. Shen, his Urology Care Foundation-supported trainees and many others at Columbia University Medical Center, we are now closer to developing individualized and more effective treatments for bladder cancer. ●

## *A Personal Investment in Bladder Cancer Research – The Kahlert Foundation*



Pictured left to right: Nicholas Smith, MD; Ronald Tutrone, MD; Greg Kahlert

Urologic cancers can have a devastating impact on patients and their families, sometimes ending in the loss of a loved one. This became all too real for Greg Kahlert, president of the Kahlert Foundation, when his father passed away from cancer. Originally diagnosed with bladder cancer, his cancer went into remission but soon resurfaced in his lymph nodes and liver, eventually taking his life in 2011. In honor of his father's commitment to giving back to the community, Mr. Kahlert and his family decided to help support cancer research with the hope that future generations wouldn't lose a parent this way. He was inspired to donate to the Urology Care Foundation after his father's urologist, Dr. Ronald Tutrone, recommended he partner with the Foundation to help find a cure for bladder cancer. "Given the Urology Care Foundation's reputation as a leader in funding cutting-edge research, this was an easy decision," Mr. Kahlert reported.

The Urology Care Foundation collaborated with Mr. Kahlert and the Kahlert Foundation to create a research award dedicated to bladder cancer. This partnership resulted in a 2017 Residency Research Award, and the Foundation selected Dr. Nicholas Smith as its inaugural recipient. During the time of his award, Dr. Smith was a urologic surgery resident at the University of

California, Los Angeles (UCLA), which is world renowned for its urologic cancer research. He aspires to have a career as a research-oriented clinical informaticist and urologist. The primary goal of his project was to improve care for patients with recurrent bladder cancer.

Mr. Kahlert had the opportunity to meet with Dr. Smith at the AUA Annual Meeting to learn more about his research, and they were both honored at the Urology Care Foundation's Research Honors Program and Reception (pictured above). Upon realizing the tremendous impact this award could have on advancing bladder cancer research as well as helping to provide Dr. Smith with critical research training, Mr. Kahlert and the Kahlert Foundation decided to continue their partnership with the Urology Care Foundation in 2018. This resulted in two more Residency Research Awards dedicated to bladder cancer research, which were awarded to Dr. Jacob Gantz at the University of Rochester Medical Center and Dr. Vishnukamal Golla at UCLA.

The Urology Care Foundation is grateful to Mr. Kahlert and the Kahlert Foundation for their shared commitment to improving the lives of patients suffering from bladder cancer. ●

## KAHLERT FOUNDATION AWARDEES AT-A-GLANCE



### Nicholas A. Smith, MD

Bladder cancer diagnosis often leads to a series of follow-up procedures that are frequently missed by patients. Dr. Smith tapped into the power of electronic health records (EHRs) at the Greater Los Angeles Veterans Hospital to study an automated bladder cancer tracking program that detects when patients fall behind on their cancer care, and assessed its potential for improving the quality of cancer care for our veteran population. This approach to population health research may be generalizable to the wider population of patients suffering from bladder cancer.

...improving the quality of cancer care for our veteran population...

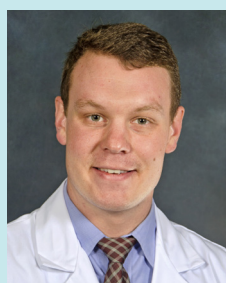

### Jacob Gantz, MD

In an effort to make cancer therapy more affordable for patients, Dr. Gantz is conducting a detailed cost analysis of treating low grade non-muscle invasive bladder cancer with gemcitabine. Gemcitabine has been proven to have the same effect of mitomycin C, a more commonly used treatment, as a form of chemotherapy to prevent the recurrence of bladder cancer following surgery. Importantly, gemcitabine is up to 37 times cheaper, making the potential cost savings for patients enormous.

...detailed cost analysis of treating low grade non-muscle invasive bladder...



### Vishnukamal Golla, MD, MPH

Dr. Golla will conduct the first evidence-based study to analyze the surgeon's role in surveillance, observing the patient over time to identify cancer recurrence, during and after chemoradiation therapy for muscle-invasive bladder cancer, and correlate these decisions with patient outcomes. Dr. Golla anticipates that this information will help inform urologic guidelines and ultimately identify new opportunities to improve patient care and survival.

...identify new opportunities to improve patient care and survival.

A photograph of a laboratory bench. In the foreground, there is a microscope with a blue eyepiece and a white base. To the right, a multi-channel pipette is visible. The background shows a wooden cabinet with various lab supplies, including boxes and containers. The overall scene is brightly lit, suggesting a clean and professional research environment.

# *Mentorship Matters*

## – Building Relationships that Bring Discoveries to Patients

High-quality mentorship is vital for any young physician scientist or researcher hoping to make a difference in patients' lives. The path to becoming a research leader is long and challenging, and a roadmap to success is never entirely drawn during graduate courses or surgical rotations. Without the proper guidance and support from more experienced investigators who have already navigated this journey, young physicians and scientists often fall short of being able to translate their new ideas into discoveries, putting the future of patient care at risk. Dr. Dolores J. (Dorrie) Lamb at Weill Cornell Medicine is truly passionate about helping early-career researchers find their way. She has devoted part of her career and life energy to providing impactful mentorship to her trainees, 18 of whom have been funded by the Urology Care Foundation.





*“Dr. Lamb simply brings out the best in the people she works with, and helps steer them in just the right direction...”*

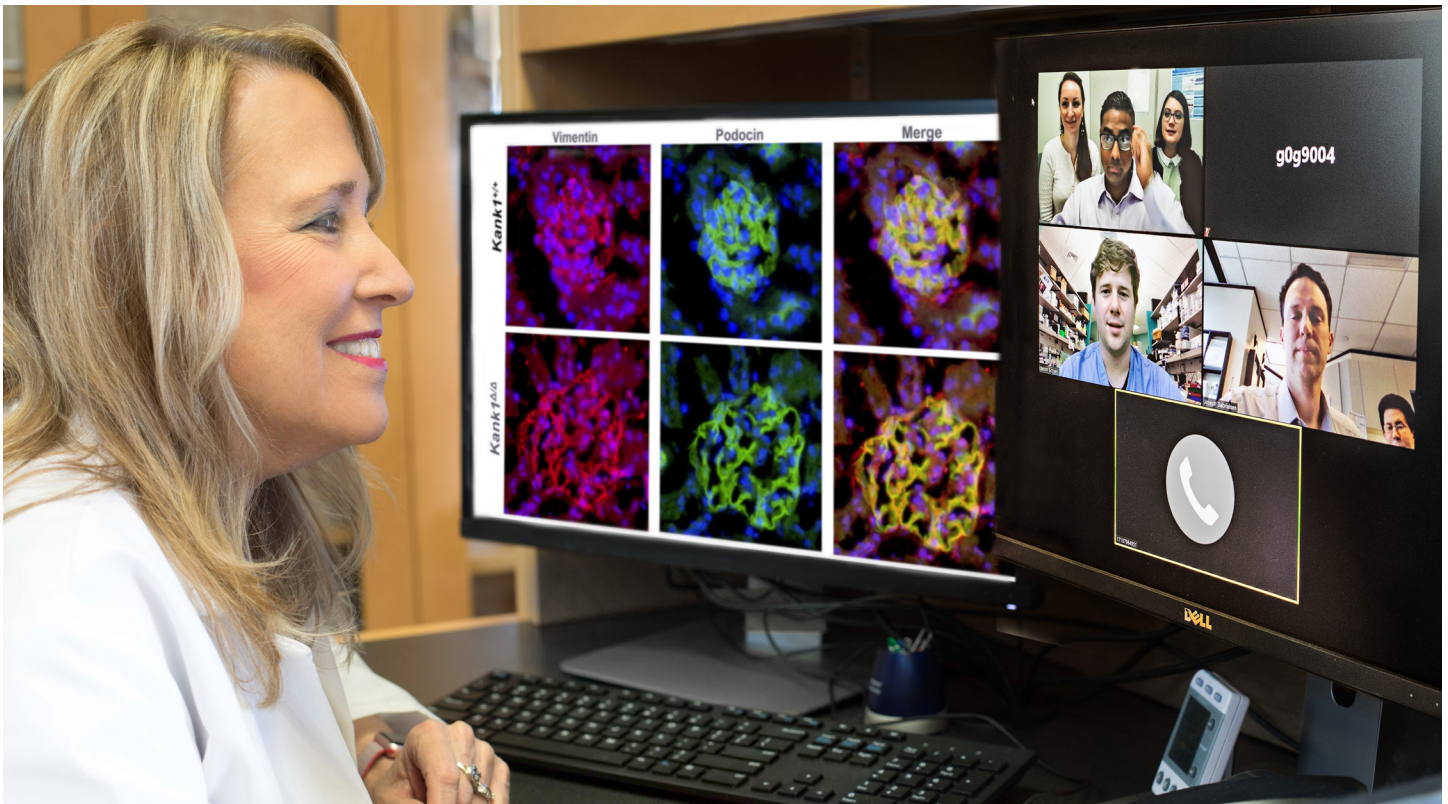

Dr. Lamb meeting with trainees online

Dr. Lamb has mentored over 200 physician scientists and researchers throughout her career. Although it's common for senior investigators to take on younger researchers in their labs to help with experiments, the development of meaningful mentorship requires much more personal commitment. She believes the key to being a great mentor is championing mentees in their chosen field while helping them to build personal and professional relationships, and ultimately embrace science as part of their life plan. Dr. Lamb learned the value of building these connections from her own mentors.

After entering graduate school, one of Dr. Lamb's mentors would frequently invite her to medical school and society events. As she was just starting out in her research career where funding is often limited for students, Dr. Lamb assumed this was her mentor's way of making sure she got a free meal! Years

later, however, she realized that what her mentor was really doing was introducing her to outstanding researchers in her field, promoting her research, and getting her name recognition. She still bumps into people to this day who remember meeting her at one of these events!

“One of the things that I really appreciate about Dr. Lamb's mentorship style is that she seeks opportunities and experiences to help us succeed and become independent,” writes J. Scott Gabrielsen, MD, PhD, Fellow in Male Reproductive Surgery and Medicine at Baylor College of Medicine. “She is constantly introducing us to people, encouraging and facilitating our participation in research and clinical societies, and is always available as a sounding board for our ideas or to give advice. Despite her busy schedule and many responsibilities, I have appreciated the genuine interest she has shown in my development and growth.”

An impactful mentor not only provides networking opportunities for their trainees, but also develops personal connections with them. Great mentors come to understand their mentees' skills and provide guidance to help shape their strengths into future careers. Mentors like Dr. Lamb view their roles as lifelong commitments to the success of the trainees and encourage the passions and creativity of their mentees to help them reach their goals. This support is especially important for practicing urologists who want to establish research labs.

“Dr. Lamb simply brings out the best in the people she works with and helps steer them in just the right direction,” writes Alexander W. Pastuszak, MD, PhD, Assistant Professor of Surgery at the University of Utah and recipient of a 2018 Urology Care Foundation Rising Stars in Urology Research Award as well as a Urology Care Foundation Research Scholar Award. “Without her guidance, many of us probably wouldn't even know what science is, let alone know how to write a paper or a grant. I can say that, without Dorrie, I probably wouldn't have continued my basic science research, and certainly would not have gotten my first NIH grant. It's just this type of persevering, successful role model that so many of us need to show us what's possible and to push us not to give up!”

In addition to serving as a mentor for individual trainees, Dr. Lamb also directed two NIH-funded Urologic and Men's Health Research Career Development Programs at Baylor College of Medicine. These programs were designed to provide urologic research training with an emphasis on translating scientific innovations to clinical applications. The programs continue to attract trainees across all career stages—from postdoctoral and clinical fellows to undergraduate students—many of whom have gone on to make important contributions to basic and translational research.

Dr. Lamb has worked in urology most of her career, studying a range of topics including male infertility, genitourinary birth defects and prostate cancer. Her extensive background in basic science research as well as clinical diagnostics in men's health has placed her in an invaluable position to help others translate their scientific ideas into medical discoveries, and the support that her trainees have received from the Urology Care Foundation is a testament to her outstanding mentorship. Dr. Lamb considers it a privilege to be a part of these individuals' careers and enjoys the opportunity to share knowledge across different fields in search of a common goal—to improve patient care. ●



Dr. Lamb has mentored over 200 physician scientists and researchers throughout her career.

# THE FUTURE

## New initiatives to advance tomorrow's practice.

While enjoying a rich history of fostering today's leaders in urology and research, the Urology Care Foundation continues to develop new education and funding initiatives toward improving tomorrow's practice. Your support enables the Foundation to make a difference in patients' lives by providing unparalleled research training opportunities that best prepare our physicians to fight urologic disease. Many of these opportunities are born out of creative collaborations with government funding organizations, industry, urology practices and other stakeholder organizations. As a leading nonprofit urologic health foundation, the Urology Care Foundation is committed to discovering the next breakthrough in patient care. Together.





## *Improving Urology Practice with Community-based Research – Chesapeake Urology Associates*

Dr. Siegel (left) and Dr. Rotinen following her presentation to the Chesapeake Urology Associates Board of Directors.

When you think about medical research, do you imagine brightly-lit laboratories, sterile equipment, or whirring super computers at a huge university or drug company? While these images are certainly part of the picture, urologists working in the community also play an important role in research. Community-based urologists comprise nearly 60% of all urologists working in the United States, and their daily interactions with patients position them to identify critical gaps in patient care and develop the research questions to help close them. Chesapeake Urology Associates, a long-time partner of the Urology Care Foundation, recently stepped up to make an impact in prostate cancer research.

Chesapeake Urology Associates is the largest urology practice in the nation and is dedicated to giving back to their local community. They hold regular educational programs focused on awareness and preventative care, and work with local churches to offer free prostate cancer screenings. These efforts are supported by their

annual ZERO Prostate Cancer Challenge, a national fundraising walk/run that brings together athletes, medical teams, cancer survivors, caregivers and other advocates. Their commitment to raising awareness and funding to end prostate cancer eventually led to a special relationship with the Urology Care Foundation.

Led by Dr. Sanford J. Siegel, Chesapeake Urology Associates is now partnering with the Urology Care Foundation to establish the Community-based Research to Advance Prostate Cancer Care Fund. This permanent fund will support workshops and conferences to help develop collaborations between private practices, academic research institutions and industry stakeholders to support prostate cancer research initiatives. Funds were most recently used to support the inaugural “Success in Community-based Urology Research: Engagement, Collaboration and Resources” workshop, which was held in Baltimore, MD. This hands-on workshop helped community urologists and their staffs learn how to start or strengthen prostate cancer clinical

trial programs in their practices. The program attracted participants from 18 different states and Ontario, Canada.

Chesapeake Urology Associates is also the only private practice to permanently fund a Research Scholar Award with the Urology Care Foundation. In recognition of their efforts to end prostate cancer, the award is restricted to funding physician scientists or researchers who are working on prostate cancer studies. There have already been two recipients of this award: Dr. Mirja Rotinen at Cedars-Sinai Medical Center who completed a two-year award in 2018, and Dr. Andrew Chin at the same institution who will complete his award in 2020. Although she

just completed her award period, Dr. Rotinen has already made an important discovery in the field (see below).

The doctors and employees of Chesapeake Urology Associates are dedicated to ending prostate cancer because they know that cancer touches everyone in some way. Unfortunately, their very own Dr. Siegel was diagnosed with prostate cancer in 2018. In honor of his commitment to giving back to the community he serves, Chesapeake Urology Associates unanimously decided to rename their Research Scholar Award in his honor. It is now known as the Chesapeake Urology Associates Sanford J. Siegel, MD Prostate Cancer Research Scholar Award. ●



Dr. Mirja Rotinen recently published an important study in the highly-prestigious Nature Medicine journal with Dr. Sungyong You, another Urology Care Foundation-funded researcher, and their mentor Dr. Michael Freeman at Cedars Sinai Medical Center. Dr. Rotinen and her colleagues confirmed that ONECUT2—a protein coding gene—controls the activity of other genetic factors related to the suppression of androgen receptor signaling. Importantly, ONECUT2 can be targeted in order to suppress aggressive, drug-resistant prostate cancer in cancerous models. This means that Dr. Rotinen and her team have identified a new opportunity to treat castrate-resistant prostate cancer.

*“My wife and I decided to designate a portion of our estate to support the Urology Care Foundation as a way to give back to an organization that has enhanced my career in Urology. I want to see my hard work translated into funds that help launch the careers of scientists and clinicians in our field. Supporting the Foundation’s initiatives is critical to advancing the work of surgeon scientists and researchers who are developing the science and tools for the future of our trade.”*

**Roger E. Schultz, MD, FACS**

*Mid-Atlantic Sectional Representative to the Board of the AUA*

# Innovations in Ureteral Stent Design Help Patients Recover Faster

A ureteral stent is a thin, flexible tube inserted into the ureter that helps drain urine from the kidney to the bladder. Stents are most often used to bypass blockages caused by kidney stones, as well as any narrowing from outside pressure (such as that caused by a tumor) or to help the ureter heal from inflammation or damage. Stents can be placed through a simple outpatient procedure thanks to past advancements, but today’s researchers continue to innovate these devices to increase the overall quality of life for patients.

## THE DOUBLE-J URETERAL CATHETER STENT

Dr. Roy P. Finney, Jr. patented the Double-J Ureteral Catheter Stent in 1980. Up until that point, ensuring that the stent did not move around was the biggest challenge when it came to patient comfort and safety. Solutions at the time included stents that had barbs along the side to secure them within the ureter or stents that extended outside of the body and were secured externally. The double-j stent was made from a flexible silicone material, allowing it to bend and move with a patient’s body. The ‘j’ or hook shape at each end prevented the stent from moving up or down, and the design reduced discomfort and inflammation during contact with the bladder or kidney wall. A wire was run through the stent to straighten and move it into position, then the wire was removed allowing each end of the stent to curl upon exit. The stent can be inserted or removed during an outpatient, endoscopic procedure, and these important innovations allowed patients to quickly return to daily life with improved comfort.



Roy P. Finney, Jr., MD

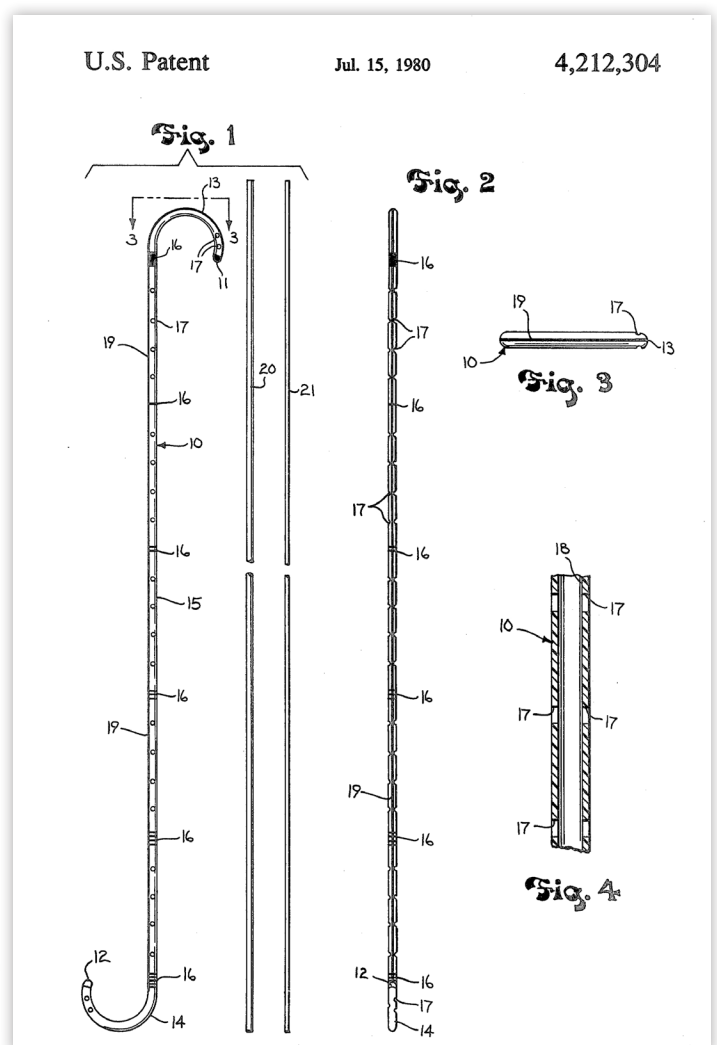

U.S. Patent 04212304, July 15, 1980



More than 80% of patients with indwelling stents complain of severe pain and discomfort, resulting in stents being removed too soon and putting the patient at risk for complications due to obstruction. Dr. Lange is working to address this issue by increasing our understanding of how the ureter responds to indwelling stents.

### DEVELOPING BIOFILM TECHNOLOGY TO FIGHT INFECTION

Dirk Lange, PhD, a 2013 Urology Care Foundation Research Scholar, is now the Director of Basic Science Research at the Stone Centre at Vancouver General Hospital where he has developed a research program to improve the lives of patients suffering from kidney stone disease. Specifically, Dr. Lange's team focuses on identifying mechanisms that drive ureteral stent-associated complications.

More than 80% of patients with indwelling stents complain of severe pain and discomfort, resulting in stents being removed too soon and putting the patient at risk for complications due to obstruction. Dr. Lange is working to address this issue by exploring how the ureter responds to indwelling stents. Device-associated infection and encrustation are two of the complications plaguing patients with indwelling ureteral stents. Much research has gone into the development of coatings and drug releasing technologies to try to overcome these issues, but all have fallen short of success when tested in patients. Dr. Lange's group was one of the first to identify urinary components that deposit on the device surface and form a film that renders any new technology ineffective. Furthermore, they showed that this film can promote bacterial and crystal attachment. Having identified the proteins that cause these technologies to fail, Dr. Lange is now focusing his efforts on developing stent coatings that not only target bacteria and crystals, but more importantly prevent the problematic film from forming and allow the underlying coating to remain active. Supporting early-career scientists like Dr. Lange demonstrates the Urology Care Foundation's commitment to promoting the development of translational research programs that improve patients' lives. According to Dr. Lange, the Foundation's support was instrumental in helping to develop his career as a urology researcher by providing him with high-caliber mentorship and connections that allowed him to take his research to the next level. ●



Dirk Lange, PhD

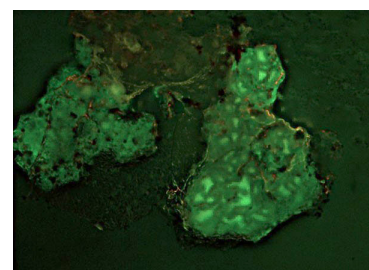

E. Coli (red) interacting with Fibrinogen (green) on the surface of a stent removed from a patient. This shows that the bacteria interact mostly with the protein rather than areas without conditioning film.

# Leading the Way to Federal Research Funding



2018 Early-Career Investigators Workshop attendees and faculty

The Foundation's support for research education initiatives, like the Early-Career Investigators Workshop, provide young researchers with skills they need to succeed.

A million-dollar idea is worth very little without the necessary investment to help transform it into reality. The same holds true for biomedical research. Federal funding from agencies, like the NIH, are considered the gold standard for future success, but these awards are highly competitive and the application process can be difficult to navigate.

Launched in 2012, the Early-Career Investigators Workshop has helped young researchers overcome these hurdles and continues to clear the path to funding success. Since then, participants have gone on to earn a combined \$8 million dollars in federal funding! More importantly, this money is being used to help find cures for urologic diseases such as urinary tract infections, prostate cancer, pediatric conditions and bladder cancer.

The Early-Career Investigators Workshop is held annually and encompasses in-depth grant writing training as well as presentations on important aspects of developing a sustainable research career. This meeting is unique because participants are paired with senior, scientific advisors for one-to-one mentoring sessions. Attendees are required to bring drafts of their current grant pro-

posals and are then paired with urology research experts who provide individualized feedback throughout the meeting. In addition, faculty members hold a mock peer-review session with real applications to show participants how their future proposals will be evaluated by federal review committees.

Workshop participants are also given the opportunity to interact with grant program officers from different institutes within the NIH to learn how to navigate grant application processes. Finally, faculty members are invited to give research career development presentations on topics ranging from establishing successful collaborations, transitioning between institutions, and how to navigate the negotiation process.

The Workshop's reputation as a high-impact educational resource is largely due to the faculty who volunteer their time and expertise to help the next generation of physician scientists and researchers. In addition, the Foundation's support helps to ensure that early-career scientists have the needed travel support, typically limited at their institutions, to attend important educational activities such as this workshop throughout the year. ●

# Reshaping Urology Research Training

The new Physician Scientist Residency Training Award is the Foundation's latest initiative providing in-depth research training to the next generation of urology surgeon scientists.

The Physician Scientist Residency Training Award is the newest addition to the Urology Care Foundation's mentored grants portfolio and was made possible thanks to an endowed partnership with Dornier MedTech. A program relatively rare in the field of urology but common in other medical and surgical fields, this award supports a three-year research training program embedded within urology residency. The focus of this program is to prepare young surgeon scientists to become successful research leaders and make impactful discoveries for their patients.

Securing federal funding is critical to make significant advances in any medical field. One of the key reasons urology lags behind in obtaining this type of support is the lack of education, training and experience necessary to design research projects that can successfully compete for funding. While the Foundation continues to provide robust support in these areas, little attention has been paid to standardizing overall research training to the same degree as clinical training.

The Physician Scientist Residency Training Award was launched in 2017 after 18 months of consulting research leaders within and outside of urology and gathering information from numerous residency programs, as well as guidance and approval from the AUA Board of Directors and the American Board of Urology. The award was first competed to academic institutions to determine which urology residency programs could provide the necessary training and support for this new program. The second phase of the competition was then opened to medical students to apply for an available residency slot at one of these institutions. ●

Following a rigorous peer-review and interview process, the Urology Care Foundation is delighted to announce that **Joel Berends, MD** was matched with the University of



Michigan to become the inaugural Physician Scientist Residency Training Awardee. Dr. Berends, who completed medical school in May 2019 from the University of Texas Health Science Center at San Antonio, will begin his residency training in July 2019. Once he completes his initial two years of clinical training, he will then matriculate, under the mentorship of faculty at the University of Michigan, into the three-year research training program consisting of didactic courses followed by a major research study. The program concludes after the final three years of clinical training.

"We are thrilled to have selected Dr. Berends as our inaugural Physician Scientist Residency Training Award recipient," said Aria F. Olumi, MD, chief of urology at the Beth Israel Deaconess Medical Center in Boston, Massachusetts, professor of surgery at Harvard Medical School, and chair of the AUA's Research Council. "He is the ideal candidate for this award and we are delighted with his selection of the University of Michigan. This new research training program further supports our ability to address the growing shortage of urology surgeon-scientists while also having a significant impact on both urology research and our patients."

# THE NUMBERS

83%

of every dollar raised is directly invested in urologic research and education programs.

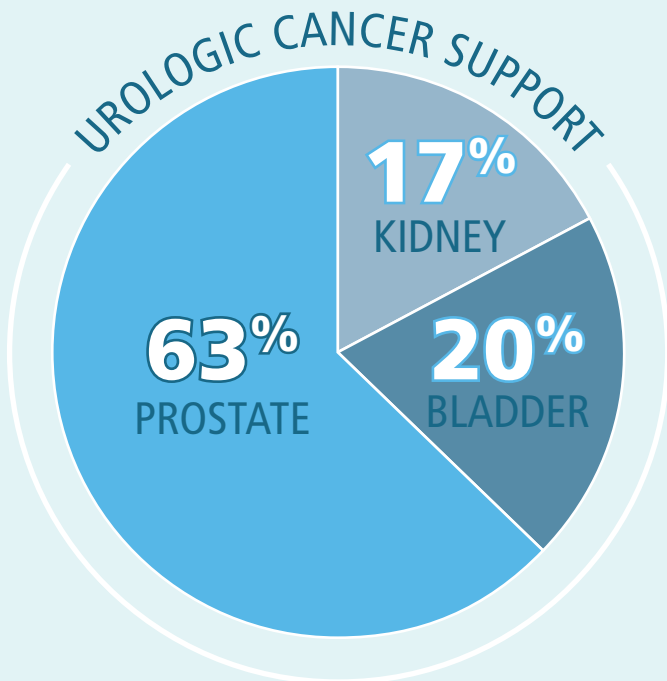

750

RESEARCHERS FUNDED  
ACROSS ALL RESEARCH  
GRANT PROGRAMS  
SINCE 1975

94%

of Research Scholars funded  
between 1991 and 2015  
agreed that  
their award was an important  
catalyst in jumpstarting their  
research careers.

## PROGRAMS IMPROVING PATIENT CARE SINCE...

Research Scholar  
Awards

Summer Medical  
Student Fellowships

Rising Stars in  
Urology Research  
Awards

1975

1996

2005

Mentorship is one of the many ways our funded investigators help foster the next generation of research leaders.

ON AVERAGE, OUR RESEARCH SCHOLAR AWARDEES GO ON TO MENTOR:

3

Faculty  
Members

8

Clinical Fellows  
and Postdoctoral  
Researchers

13

Urology  
Residents

13

Medical  
Students

## RESEARCH SUPPORT FOR BENIGN AND CANCER DISEASES

Benign Conditions: 49%

Malignant Conditions: 51%

90+

urology research experts advise the Urology Care Foundation in any given year to ensure that **each program will advance urologic research to improve patient care.**

Endowment-level funding is the most effective and stable way to support advances in urology research. The Urology Care Foundation and its sponsors have contributed to

30+

**endowments that support research education and funding opportunities** across the spectrum of urologic diseases and conditions.

Residency Research  
Awards

Physician Scientist  
Residency Training  
Award

What's Next? Your  
gift could lead to the  
next big breakthrough.

2010

2017

# Our Sponsors

The Urology Care Foundation's ability to advance patient care through research would not be possible without the continued generosity of our partner organizations and donors. Science is a team effort and the past two years of support provides only a snapshot of the far-reaching impact the Foundation's research awards have on improving patients' lives.

## Rising Stars in Urology Research Awards

### Astellas Pharma US, Inc.

2015-2018	Lysanne Campeau, MDCM, PhD
2016-2020	Matthew J. Resnick, MD
2017-2019	Hao Nguyen, MD, PhD
2018-2021	Alexander W. Pastuszak, MD, PhD
2018-2023	Timothy Daskivich, MD

### Frank and Marion Hinman Urology Research Fund

2015-2019	Christopher E. Barbieri, MD, PhD
2017-2021	Vijaya Vemulakonda, MD

## Research Scholar Awards

### AUA Mid-Atlantic Section

*William D. Steers, MD Research Scholar Award*

2017-2019	Evaristus C. Mbanefo, PhD
-----------	---------------------------

### AUA New England Section

2017-2019	Zongwei W. Wang, PhD
-----------	----------------------

### AUA New York Section

*E. Darracott Vaughan, Jr., MD Research Scholar Award*

2016-2018	Ryan K. Flannigan, MD
2018-2020	Jonathan Shoag, MD

### AUA Northeastern Section

2017-2019	Marianela G. Dalghi, PhD
2018-2019	Jennifer Bjazevic, MD

### AUA North Central Section

2016-2018	Christina B. Ching, MD
2018-2020	Bethany Baumann, PhD
2018-2020	Anna Sintsova, PhD

### AUA Southeastern Section

2016-2018	Paul R. Dominguez Gutierrez, PhD
2017-2019	Hooman Sadri-Ardekani, MD, PhD
2017-2019	Ning Zhao, PhD
2018-2020	Brent Winship, MD

### AUA South Central Section

2016-2018	Eugene K. Lee, MD
2018-2019	Nida Iqbal, PhD
2018-2019	Justin Matulay, MD

### AUA Western Section

2016-2018	Hosu Sin, PhD
2017-2019	David C. Johnson, MD, MPH
2018-2020	Ken Batai, PhD

### Chesapeake Urology Associates

*Sanford J. Siegel, MD Prostate Cancer Research Scholar Award*

2016-2019	Mirja S. Rotinen, PhD
2018-2020	Andrew Chin, PhD

### Dornier MedTech

2016-2018	Laura A. Mike, PhD
2018-2020	Haiying Li, PhD

### Endourological Society

2016-2018	Scott R. Manson, PhD
2018-2020	William Donelan, PhD
<i>Joseph Segura, MD Scholarship in Endourology and Stone Management</i>	
2016-2018	Kyle D. Wood, MD
2018-2019	Tim Large, MD
<i>Raju Thomas, MD Research Scholar Award</i>	
2017-2019	Kymora Scotland, MD, PhD

### Indian American Urological Association

<i>Sakti Das, MD Research Scholar Award</i>	
2018-2019	Parul Aggarwal, PhD
<i>Anupam Ted Kedia Research Scholar Award</i>	
2017-2018	Vivek Narayan, MD
2018-2020	Debasish Sundi, MD

### Sexual Medicine Society of North America

2016-2018	Ranjith Ramasamy, MD
2018-2020	Serkan Karakus, MD

**Society for Pediatric Urology***Sushil Lacy, MD Research Scholar Award*

2017-2019 Elias Wehbi, MD

**Society of Urodynamics, Female Pelvic Medicine & Urogenital Reconstruction***Hari Badlani Research Scholar Award*

2017-2019 James A. Hokanson, PhD

**Society of Urologic Oncology**

2016-2018 Suk Hyung Lee, PhD

2016-2018 Geoff Sonn, MD

2017-2018 William B. Tabayoyong, MD, PhD

2018-2019 Shawn Dason, MD

2018-2020 Brandon Manley, MD

2018-2020 Karen Wheeler, MD, PhD

**Robert J. Krane, MD Research Scholar Award**

2016-2018 Adriana Vidal, PhD

2018-2019 Tariq Khemees, MD

**Residency Research Awards****The Kahlert Foundation**

2017-2018 Nicholas A. Smith, MD

2018-2019 Jacob Gantz, MD

2018-2019 Vishnukamal Golla, MD, MPH

**The Estate of Russell Scott, Jr., MD**

2017-2018 Duncan R. Morhardt, MD, PhD

2018-2019 Dima Raskolnikov, MD

**Physician Scientist Residency Training Award****Dornier MedTech**

2019-2027 Joel Berends, MD

**Summer Medical Student Fellowships****Arkansas Urologic Society**

2017 Jordan L. Fielding

2017 Michael B. Franzetti

2017 Kayln D. Holloway

2018 Morgan A. Gongola

2018 Christopher C. Randall

2018 Brittany Roses

2018 Morgan D. Sweere

**Florida Urological Society**

2017 Kush Panara

2018 Vincent M. Roth

**Herbert Brendler, MD Research Fund**

2017 Zachary R. Dionise

2017 Andrew T. Gabrielson

2017 Dylan S. Isaacson

2017 Viranda H. Jayalath

2017 Taylor P. Kohn

2017 Andrew Orlando

2017 Emily Rose

2017 Andrew Truong

2017 Daniel G. Wong

2018 Arash Amighi

2018 Manuel Armaz Villaneda

2018 Michael A. Bell

2018 Carter Boyd

2018 Joshua A. Caldwell

2018 Anna Faris

2018 Zachary Kornberg

2018 David-Dan Nguyen

2018 Jayce Ann Q. Pangilinan



*Be a Part of the Next  
Breakthrough*

“I personally believe that the return on investment of my donations to the Foundation’s research initiatives is higher than any other nonprofit organization in terms of improving the health and care of patients with urologic disorders.”

*Hunter Wessells, MD, FACS*

*Professor and Chair*

*Department of Urology, University of Washington*

*Learn more at*  
**UrologyHealth.org/Research**

*For more information, please contact:*

**Emily Boyce**

Major Gifts and Planned Giving Manager

1000 Corporate Blvd.,  
Linthicum, MD 21090

410-689-4034

EBoyce@UrologyCareFoundation.org